

Exam 2 reviewInformation you may need (given on exam):

$$h = 6.626 \times 10^{-34} \text{ J s}$$

$$k = 8.99 \times 10^9 \text{ N m}^2/\text{C}^2$$

$$e = 1.6 \times 10^{-19} \text{ C}$$

$$m_e = 9.11 \times 10^{-31} \text{ kg}$$

$$hc = 1240 \text{ eV nm}$$

$$1 \text{ eV} = 1.602 \times 10^{-19} \text{ J}$$

$$R = 8.31 \text{ J}/(\text{K mol})$$

$$k_B = 8.62 \times 10^{-5} \text{ eV / K}$$

$$k_B = 1.38 \times 10^{-23} \text{ J / K}$$

$$k_B = R / N_A$$

$$I = \frac{1}{2} c \epsilon_0 E_0^2$$

$$I = \Gamma_{ph} h\nu$$

$$\Gamma_{ph} = \frac{\Delta N_{ph}}{A \Delta t}$$

$$-\frac{\hbar^2}{2m} \frac{\partial^2 \Psi(x,t)}{\partial x^2} + V(x,t) \Psi(x,t) = i\hbar \frac{\partial \Psi(x,t)}{\partial t}$$

$$-\frac{\hbar^2}{2m} \frac{d^2 \varphi(x)}{dx^2} + V(x) \varphi(x) = E \varphi(x)$$

Infinite square well:

$$\Psi(x,t) = (Ae^{ikx} + Be^{-ikx})e^{-iEt/\hbar}$$

$$E_n = \frac{\hbar^2 n^2}{8mL^2}$$

Hydrogenic atom:

$$\Psi(x,t) = (Ae^{\alpha x} + Be^{-\alpha x})e^{-iEt/\hbar}$$

$$E_n = -\frac{me^4 Z^2}{8\epsilon_0^2 \hbar^2 n^2} = -\frac{Z^2 E_1}{n^2} = -\frac{Z^2 (13.6 \text{ eV})}{n^2}$$

Tunneling:

$$\Delta x \Delta p_x \geq \hbar$$

$$\Delta E \Delta t \geq \hbar$$

$$\alpha^2 = \frac{2m(V_0 - E)}{\hbar^2}$$

Information you should know (NOT given on exam):

$$\text{Intensity} = \text{Power}/\text{Area}$$

$$\text{Power} = \text{Energy}/\text{time}$$

$$N_{\text{photons}} = E_{\text{total}} / E_{\text{photon}}$$

$$\Delta L = n\lambda$$

$$\Delta L = \left(n + \frac{1}{2}\right)\lambda$$

$$2d \sin \theta = n\lambda, \quad n = 1, 2, 3, \dots$$

$$KE = \frac{1}{2} mv^2 = q\Delta V$$

$$KE_{\text{max}} = h\nu - \Phi$$

$$E = h\nu = \frac{hc}{\lambda}$$

$$p = \hbar k = h/\lambda$$

$$k = 2\pi/\lambda$$

$$V(r) = -\frac{kZe^2}{r}$$

$$\text{probability} \sim e^{-E/kT}$$

$$e^{ikx} = \cos(kx) + i \sin(kx)$$

1. For a hydrogenic atom, the energy levels are given by $E_n = -E_0 Z^2 / n^2$. Give physics reasons why there is a Z^2 dependence in this equation. Your answer should cover both why it would only make sense for it to contain Z , and reasons why it makes sense that it should be squared in the equation, rather than some different power.

2. Suppose you have an electron and a photon both moving through space with a kinetic energy of 5eV.

a. What is the deBroglie wavelength in nm of the photon?

b. What is the deBroglie wavelength of the electron (in nm)?

3. You are walking briskly across campus for your next class. What is your approximate deBroglie wavelength in meters?

4. A free electron is generally described by the wave function $\psi(x,t) = Ae^{ikx}e^{i\omega t}$. At $t=0$, this is $\psi(x) = Ae^{ikx} = A \cos(kx) + A i \sin(kx)$. For this wave function, a bigger k ... (check all that apply)

- means a bigger wavelength
- means a smaller wavelength
- has no effect on wavelength
- means a smaller momentum
- means a larger momentum
- has no effect on momentum
- means less KE
- means more KE
- has no effect on KE

5. a) A plane wave has: (check all that apply)

- large uncertainty in position
- small uncertainty in position
- large uncertainty in momentum
- small uncertainty in momentum

b) Relative to a plane wave, a wave packet has: (check all that apply)

- larger uncertainty in position
- smaller uncertainty in position
- larger uncertainty in momentum
- smaller uncertainty in momentum

6. How does thinking of electrons as waves rather than particles explain why energy levels in the hydrogen atom are quantized? How does it answer Bohr's question of why electrons don't radiate energy when they are in one of these energy levels?

7. A low energy electron sitting in a ccd pixel of a digital camera has a wave function of approximately the following functional form:

$$\begin{aligned} \psi &= ce^{(x+d)/L} && \text{for } x < -d \\ \psi &= c && \text{between } x = -d \text{ and } x = d \\ \psi &= ce^{-(x-d)/L} && \text{for } x > d \end{aligned}$$

Draw the wave function and calculate what c needs to be in terms of L and d in order for the wave function to be properly normalized.

8. The work function of copper is 4.7 eV. Which of the following could be a plot of potential energy vs. position for an electron in a copper wire of length L surrounded by air on either side? (Check all that apply)

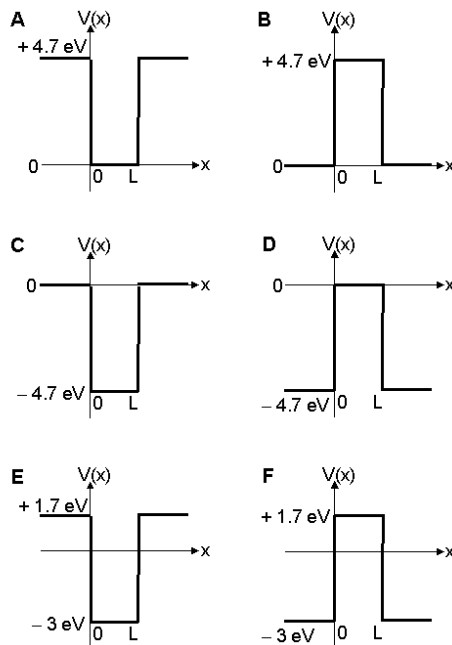

9. An infinite square well would be the exact potential energy function for:

- A. an infinitely long wire
- B. a really really short wire
- C. an infinitely thick wire
- D. a really really thin wire
- E. a wire made out of a metal with an infinite work function
- F. a wire made out of a metal with a work function of zero

10. In class we solved Schrodinger's equation to get the wave functions for an electron trapped in an infinite one-dimensional square well potential. This potential is a reasonable approximation of the potential energy for an electron in an isolated segment of wire.

a. If the wire is length L , what wavelengths are allowed for the wave function of the electron?

b. Why does this restriction on the wavelengths lead to a quantization of the possible energies an electron can have in the wire? Show how to determine these quantized energies from the quantized wavelengths (include the final express for the quantized energies)? (Be sure to explain your reasoning)

c. What is the smallest possible energy (in eV) – the ground state - for an electron in a 0.01 m (1 cm) wire?

d. How much energy (in eV) does an electron at room temperature (300K) have? Recall (from the equipartition theorem) that the average thermal energy of an electron is given approximately by $(3/2)kT$ where k is Boltzmann's constant.

e. What length wire (in nm) would have the energy difference (energy spacing) between the ground state energy level and the next energy level up is equal to this thermal energy of an electron at room temperature?

f. Looking at the electrons energy levels in the wire:

True False As the wire gets longer, the wavelength of the electron in the lowest energy state gets longer.

True False As the wire gets longer, the ground state energy level gets lower.

True False As the wire gets longer, the energy differences between the energy levels get larger.

True False For a wire that is 1 foot long, there will be many, many (much more than a million) allowed energy levels between the ground state energy and that plus the thermal energy of an electron at room temperature.

True False The energy of level 3 ($n=3$) is 9 times the energy of the ground state energy.

True False If you halve the length of the wire, the energy of the ground state increases by a factor of 4.

True False If you double the length of the wire, the energy spacing between levels $n=1$ and $n=2$ will decrease and be equal to 0.5 times what it was.

True False The quantization of energy levels and the fact there is a gap between allowed levels only become large and important (relative to the typical thermal energies important in describing the behavior of the electron) when the length of the wire becomes submicroscopic as it does in nanotechnology.

11. The correspondence principle states that as the scale of things becomes larger, the behavior predicted by quantum mechanics must match the behavior predicted/observed in classical mechanics. So in the case of something in a potential well, explain what happens in terms of the quantum behavior as you make the well wider or you make the particle more massive that makes it look more and more classical in its behavior.

12. Below is shown a snap shot of a small segment of the real part of the wave functions for 3 different electrons. (Note these are completely delocalized so extend from $-\infty$ to ∞).

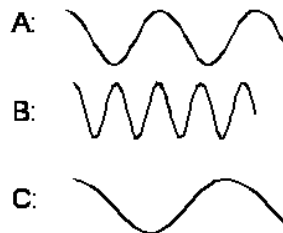

a. Which has the most KE?

A B C

b. For which is the wave number k largest?

A B C

c. If we know the electron is traveling to the right, which of the constants in the equation for $\psi(x,t)$ (A or B) must be zero? That is, which of the two terms represents a wave traveling to the left and which represents a wave traveling to the right (you can think about which way the real part of the term would travel).

$$\Psi(x,t) = (Ae^{ikx} + Be^{-ikx})e^{-iEt/\hbar} = (Ae^{i(kx - Et/\hbar)} + Be^{-i(kx + Et/\hbar)})$$

$$A = 0 \quad B = 0$$

13. Suppose that in the infinite square well problem, you set the potential energy at the bottom of the well to be equal to some constant V_0 , rather than zero.

a. Write the time-independent Schrödinger Equation inside the well:

b. What are the energy levels for the infinite square well of width L with potential energy equal to V_0 at the bottom of the well?

c. Why is it that in most cases we only have to solve the time-independent Schrodinger equation instead of the more complicated time-dependent Schrodinger equation? (Check all that apply.)

- Time just isn't that important.
- In most cases the potential is not time dependent.
- In most cases the wave function is not time dependent.
- In most cases we only want to look at what happens at one particular instant in time.
- The time dependent Schrodinger equation is impossible to solve.
- If the potential is not time dependent, the time dependent part of the wave function is always the same.
- We already solved for the time dependent part of the wave function last week, so we don't have to calculate it again.

14. An electron is bound in a potential well. The wave function of the electron is $\psi(x,t) = \varphi(x)e^{-i\omega t}$ where $\varphi(x)$ is shown below and ω is a real number.

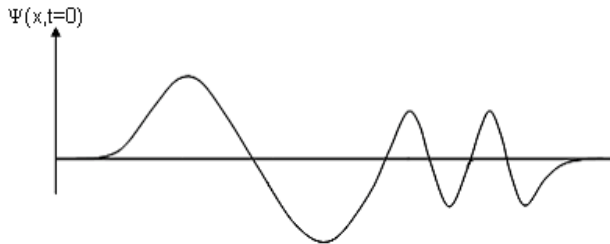

a. Which plot of $V(x)$ vs. x below could represent the potential well in which this electron is bound?

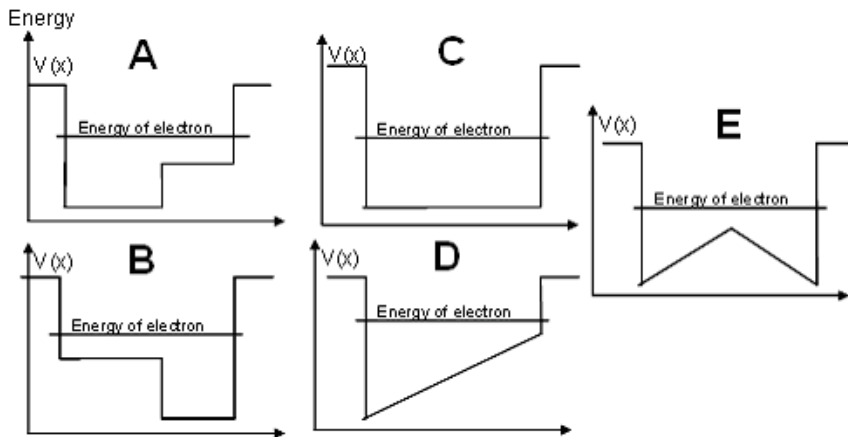

b. Explain your reasoning.

c. Mathematically, choosing $\Psi(x,t) = [A\cos(kx) + B\sin(kx)]\exp(-i\omega t)$ is equivalent to choosing $\Psi(x,t) = [A'\exp(ikx) + B'\exp(-ikx)]\exp(-i\omega t)$. Sometimes it's just more convenient to choose one or the other. Suppose we made one choice and wanted to convert to the other choice. What are A and B in terms of A' and B' ?

15. a) What is the uncertainty in position for an electron in the $n = 1$ state of an infinite square well of length L ?

b) What is the uncertainty in momentum?

c) Does the electron violate the uncertainty principle? Explain your reasoning.