

Rotation – Set 4

Below are several objects. Each circle is a point mass, and each point has the same mass. The connecting rods are massless. Rank them in order of their *moment of inertia*, least to most. If any have the SAME moment, give them the same ranking number. **Explain your reasoning.**

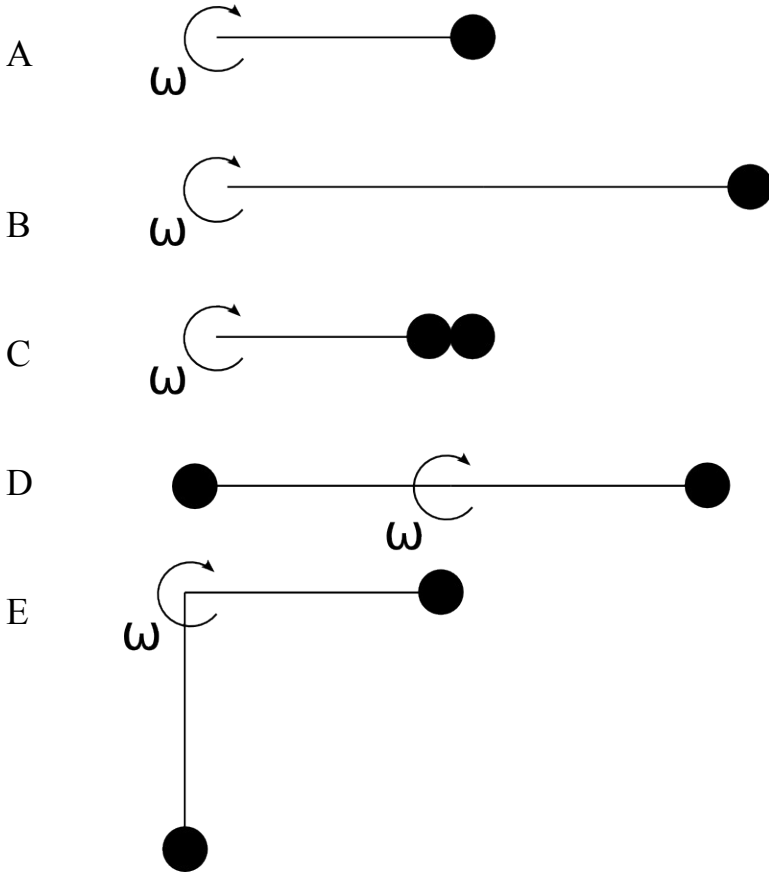

Rotation – Set 4

In the pictures below, two masses are connected by a massless rod and the system is allowed to rotate about the pivot shown. The large circle is more massive than the small circle. The same magnitude force is applied to each system as shown in the diagram.

Rank the three systems in order of the applied *torque*, least to most. **Explain your reasoning.** If any have the SAME torque, give them the same ranking.

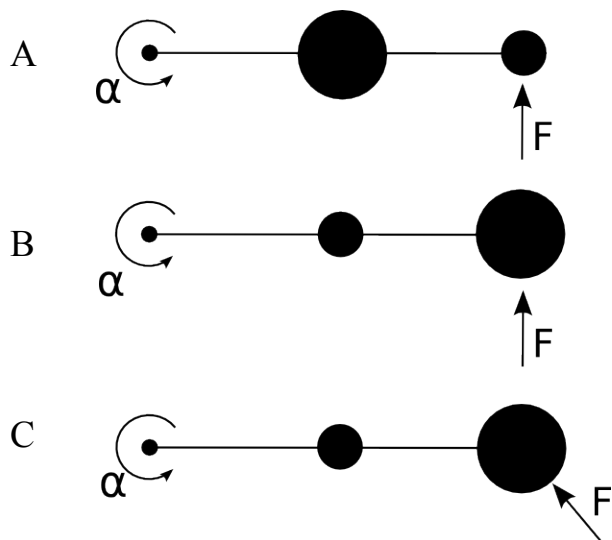

Rank the three systems in order of the applied *torque*, least to most. **Explain your reasoning.** If any have the SAME torque, give them the same ranking.

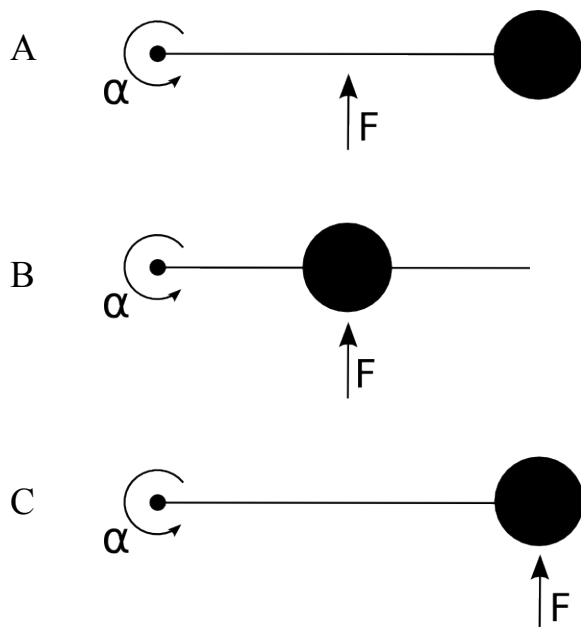

Rotation – Set 4

3

In the pictures below, two masses are connected by a massless rod and the system is allowed to rotate about the pivot shown. The large circle is more massive than the small circle. A force is applied to each system as shown in the diagram.

Rank the three systems in order of their *angular accelerations*, least to most. **Explain your reasoning.**

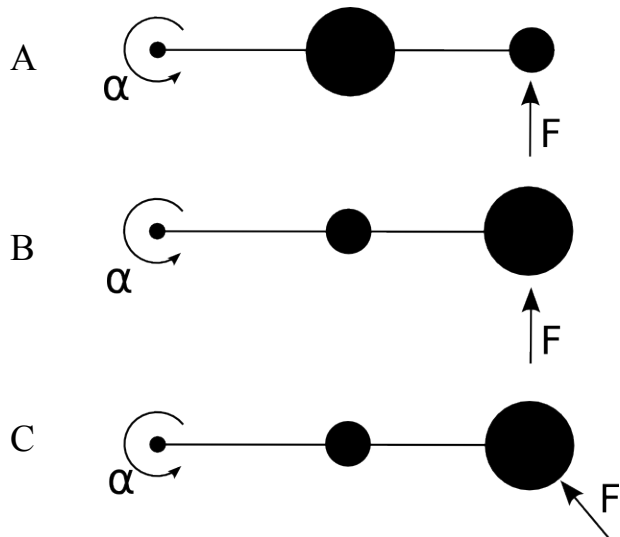

Rank the three systems in order of their *angular accelerations*, least to most. **Explain your reasoning.**

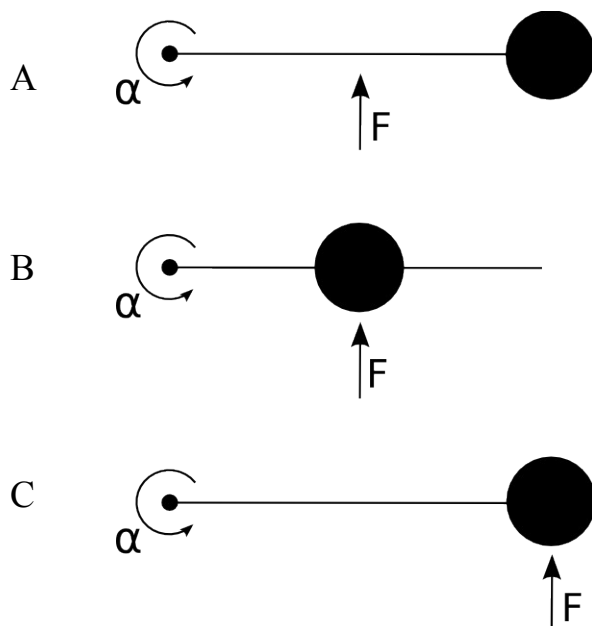

Rotation – Set 4

4

Use **Newton's Second Law and Kinematics** to solve this problem.

A block of mass M is at rest on a frictionless surface. A massless string is attached to the block, passes over a small massless frictionless pulley, and is attached to a small mass m .

What will the velocity block on the surface be after the hanging mass falls through a distance d ?

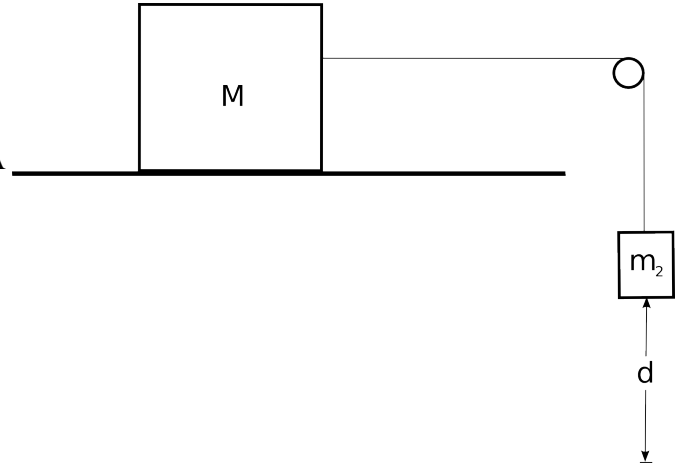

Rotation – Set 4

Use **Torque and Kinematics** to solve this problem.

A solid cylinder of mass M , radius R , and moment of inertia $I = \frac{1}{2}MR^2$ is allowed to rotate without friction about an axis through its center as shown. A massless string is wrapped around the cylinder, passes over a small massless frictionless pulley and is attached to a small mass m .

If the mass and the cylinder start from rest, what will the angular velocity of the cylinder be after the mass falls through a distance d ?

Compare your answer to your result from **Conservation of Energy** (Packet 3)

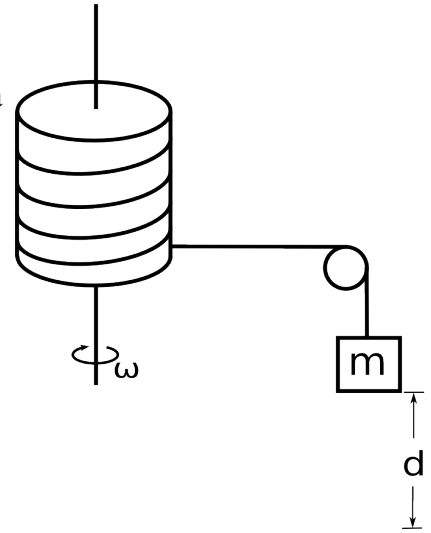

Rotation – Set 4

6

Use **Torque and Kinematics** to solve the following problem.

Two masses are connected by a light string passing over a frictionless pulley. the Mass m_2 is released from rest at a height of 4.0 m above the ground. You can treat the pulley as a solid disk.

Determine the speed of m_1 as m_2 hits the ground.

$$m_1 = 3.0 \text{ kg}$$

$$m_2 = 5.0 \text{ kg}$$

$$m_{\text{pulley}} = 0.5 \text{ kg}$$

$$r_{\text{pulley}} = 0.1 \text{ m}$$

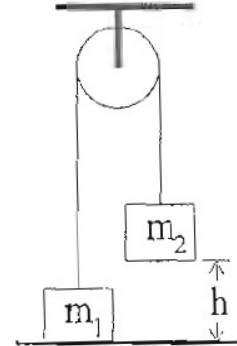

Rotation – Set 4

7

A cylinder with a mass of 2.0 kg can rotate about its central axis through the point O . Forces are applied as in the figure below. $F_1 = 6.0$ N, $F_2 = 4.0$ N, $F_3 = 2.0$ N, $F_4 = 5.0$ N, $R_1 = 5$ cm, $R_2 = 12$ cm. Find the direction and the magnitude of the angular acceleration of the cylinder. (During rotation, the forces maintain the same angles relative to the cylinder.)

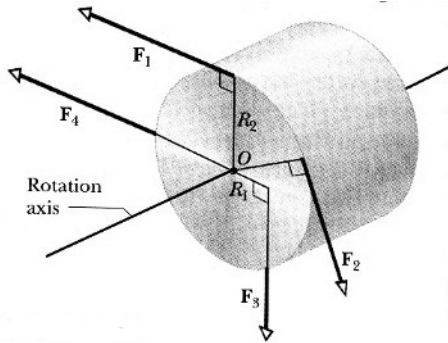

A door has a mass of 50 kg and is 0.8 m wide. The moment of inertia is $I = 1/3 MW^2$ where W is the width of the door. I push on the door with a constant force of $F = 10$ N in two places; in the middle of the door a distance $W/2$ from the hinge and at the knob, a distance W from the hinge.

- a) Draw free body diagrams of the two cases.
- b) What is the magnitude of the Torque for each case?
- c) What is the magnitude of the angular accelerations for each case?
- d) How much time does it take the door to rotate through 90° in each case?
- e) How much force would I have to apply at $W/2$ so that the door rotated through 90° in the same amount of time as applying 10 N to the knob?